

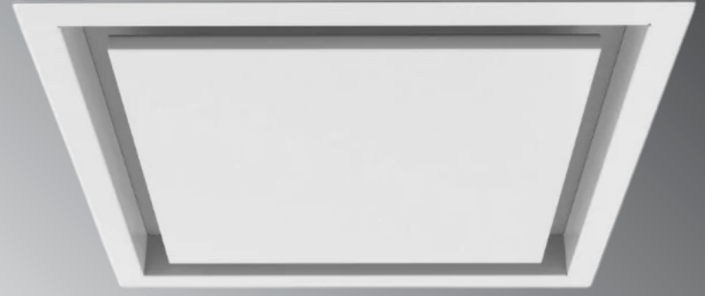

Sirius



UNIVERSAL RANGE

SBE1-WH

350MM ONBOARD UNIVERSAL EXTRACTOR

SPECIFICATIONS

Rangehood Type	Universal Extractor
GTIN	9351116001360
Country of Origin	Hand-Crafted in Italy
Suits Room Type	Bathroom, Laundry, Butlers Pantry, Work Sheds
Recommended Install Height	min 2400
Finish	White
Controls	Switch
Speed Settings	1
Recirculating	No
Filter Type	Mesh
Noise Level*	approx. 45dBA to 63dBA
Lighting	None
Automatic Shut-Off	No
Electrical Requirement	10AMP
Max Current (W)	140W
Motor Options	Onboard
Motor Extraction Rate#	350m ³ /h
Ducting Options	Top
Ducting Size	125mm diameter
Product Dimensions (mm)	H210 x W350 x D350
Nett Weight	10kg
Carton Dimensions (mm)	H250 x W400 x D400
Gross Weight	12kg
Warranty	3 Years - 6 Years if paired with Sirius Ducting

LINE DRAWING

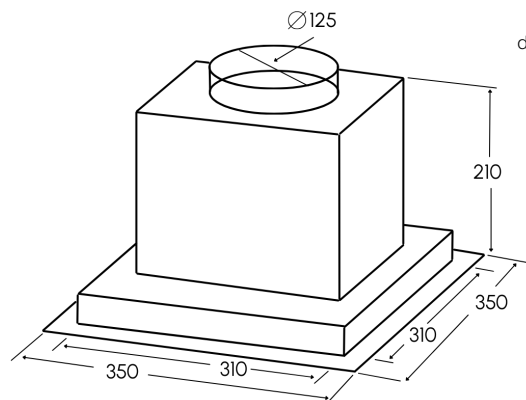

Recommended cut-out dimensions 325 x 325mm

*Extraction rate is an approximate figure and varies depending on installation.
*Please note noise level is an approximate range and subject to installation and surrounding materials.
For more information, visit our website.

KEY FEATURES



Onboard Green Energy Motor

Our revolutionary technology paired with advanced engineering generates greater air movement with less fan movement, creating a superior environment wherever you need air extraction.



Powerful Airflow

With impressive airflow and control, this air extractor quickly and effectively removes smoke, steam, heat, odours, and other airborne particles from the room.



Switch Control

The simplicity of filtering the air with the flick of a switch. This rangehood is connected to the same power that controls your lights. This exhaust fan can also be connected to the same switch as the rooms light for convenient and consistent ventilation.



Aluminium Filters

Ideal for providing superior filtration capabilities where needed with layers of metal grids that capture steam, airborne particles, odours, grease, smoke and more.



Slimline Design

Seamlessly hides away and blends in with your ceiling, with powerful extraction to remove steam, smoke, odours and grease. It's the perfect design for any bathroom, butlers pantry, laundry or work space that combines functionality and style.



European Made Motor

Partnering with the best European motor manufacturers to create the ultimate range of motors that provide the maximum in performance without the noise, that are specifically designed for the Australian home.



Hand-Crafted in Italy

Quality, functionality, innovation, style & luxury hand-crafted in Italy. Leading the market in design and functionality, this collection has been specifically handpicked for Australian living.

DUCTING SOLUTIONS

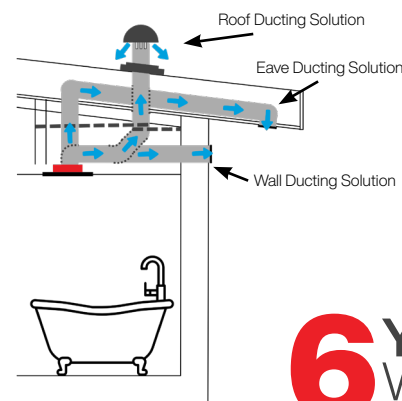

Sirius has its own range of ducting components, designed to get the most power and efficiency out of its hoods. The full range of high quality, cost effective ducting will provide you with the best result for your rangehood.

Visit us for more information

6 Year Warranty
when Sirius ducting is used

